

**MOTOR SPECIFICATION SHEET**

MODEL : CHHM10-6175-43 (LT) (Motor model : SF-JRG 10HP 4P)

USED FOR : GEAR MOTOR

DESCRIPTION	DETAIL				
PHASE	3				
MODEL NAME	CHHM10-6175-43				
RATED OUTPUT, HP (kW)	10 (7.5)				
POLE	4				
CODE	MEATH CODE : 1G1043-100H61752				
OUTLINE DRAWING NO.	OMM24O974-*				
RATED VOLTAGE (V)	220	380	415	220	440
RATED FREQUENCY (Hz)	50	50	50	60	60
RATED CURRENT (A)	27.0	15.4	14.6	26.0	13.5
RATED SPEED (min <sup>-1</sup> ) *	33	33	33	40	40
THERMAL CLASS	155(F)				
RATING	S1 (CONTINUOUS)				
ENCLOSURE CONSTRUCTION	TOTALLY ENCLOSED FAN COOLED				
DEGREES OF PROTECTION	IP55				
METHOD OF COOLING	IC411				
FRAME NO.	132S				
WEIGHT (kg)	155				
STANDARD	IEC 60034-1, JEC-2137-2000				
INSTALLATION	FOOT MOUNTED				
ROTATION	CCW (VIEWED FROM SHAFT END)				
BEARING	LOAD SIDE : 6308ZZ				
	OPPOSITE SIDE : 6207ZZ				
BEARING GREASE	UREA GREASE				
CIRCUMSTANCE CONDITION	AMBIENT TEMPERATURE : -20 ~ +40°C				
	AMBIENT HUMIDITY : 95%RH OR LESS				
	ABOVE SEA LEVEL : 1000m OR LESS				
	ENVIRONMENT : NO BURSTING/EROSIVE GAS OR VAPOR				
COLOR	MUNSELL N5.5 (GRAY)				
TERMINAL BOX	NO. OF LEAD WIRES : 6				
	SOURCE CONNECTION : TERMINAL BLOCK				
INSULATION RESISTANCE	BY DC 500V MEGGER - ≥100MΩ				
DIELECTRIC TEST	AC 50Hz 1800V - 1min. (Based on rated voltage 380V)				
GEAR RATIO	1 : 43				
GEAR LUBRICANT	OIL (Must be filled by user.)				
SERVICE FACTOR	1.51				
MATERIAL	FRAME : STEEL PLATE				
	BRACKET (GEAR SIDE) : CAST IRON				
	BRACKET (OPP SIDE) : ALUMINIUM				
	GEAR CASE : CAST IRON				
	SHAFT (MOTOR) : STEEL				
	SHAFT (GEAR OUTPUT) : STEEL				
	STATOR CORE : ELECTRICAL STEEL				
	WIRE : ENAMELLED COPPER MAGNET WIRE				
	INSULATOR : POLYESTER FILM SATURATED WITH RESIN				
	VARNISH : EPOXY DENATURALIZATION POLYESTER				
	ROTOR CORE : ELECTRICAL STEEL				
	CONDUCTOR : ALUMINIUM				
	TERMINAL BOX : STEEL PLATE				
PAINTING : POLYURETHANE RESIN					
PRODUCTION COUNTRY	THAILAND				

\* This value is calculated by MOTOR RATED SPEED / GEAR RATIO.

( Catalog value is specified by follow Gear maker specification, 50/60Hz = 34/41min<sup>-1</sup>. )

Specifications subject to change without notice.

SPECIFICATION SHEET NO.				
SS-M-2453-A				

**MODEL CHHM THREE PHASE INDUCTION MOTOR OUTLINE DRAWING**

**GEAR MOTOR**

**TOTALLY ENCLOSED FAN COOLED**

**DEGREES OF PROTECTION IP55**

**DUST & WATER JET PROOF**

**CUSTOMER**

**USER**

**FOR**

**CUSTOMER'S**

**ORDER NO.**

**QUANTITY**

**MFG.**

**ORDER NO.**

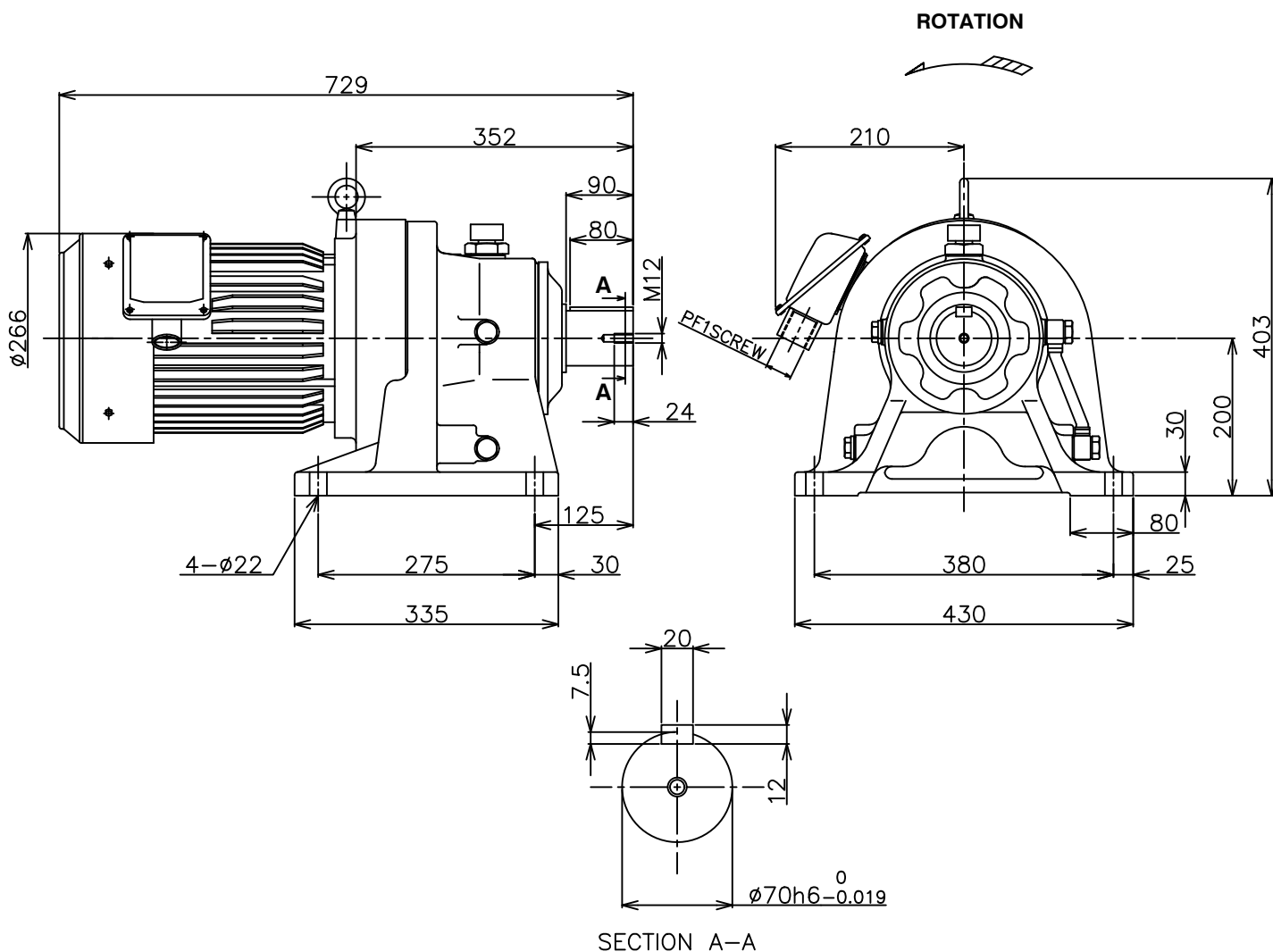

YOUR ORDER	MOTOR FRAME SIZE	RATING	TH. CLASS	AMB. TEMP	BEARINGS		COLOR	DIRECTION OF ROTATION	NO. OF LEAD WIRES	REMARKS
					LOAD SIDE	OPP. SIDE				
	132S	S1 (CONT.)	155(F)	40°C	6308ZZ	6207ZZ	GRAY (MUNSELL N5.5)	CCW	6	

YOUR ORDER	MODEL NAME	RATIO	SERVICE FACTOR	MOTOR OUTPUT		POLE	HERTZ	VOLT	OUTPUT SPEED (rpm)	LUBRICATION TYPE	WEIGHT (kg)
				HP	kW						
	CHHM10-6175-43	1:43	1.51	10	7.5	4	50	220/380/415	34	OIL <sup>(1)</sup>	155
							60	220/440	41		
	CHHM10-6175-43	1:43	1.51	10	7.5	4	50	380/415	34		
							60	380/440	41		

NOTE : (1) Please fill in Oil before first time usage (See detail in the Instruction Manual)

**MITSUBISHI ELECTRIC AUTOMATION (THAILAND) CO., LTD.**

		OUTLINE DRAWING NO. <b>0 M M 2 4 0 9 7 4</b>	REV. <b>*</b>
	DIMENSION IN mm. SCALE : NTS		